

DESCRIPTION

The Badger Meter[®] M7600 flow meter combines the most advanced electromagnetic flow metering technology with a simple, yet robust, output for batching systems found in industrial applications.

Based on Faraday's Law of electromagnetic induction, M7600 meters can accurately measure and control most batching needs in the industrial market. Its completely open cross-section flow tube design with no moving parts, makes it the ideal metering device for batching of a wide range of industrial conductive fluids.

While other metering technologies are hindered by the presence of suspended solids in the process fluid, the M7600 will continue to measure flow, provided the conductivity remains higher than 5 microhms/cm. Having a non-obstructive flow-through pipe design allows particulates to pass through the meter body. The signal voltage, measured by the electrodes, passes through the entire cross sectional profile for improved accuracy.

The M7600 meter features an intuitive PC interface used for selecting the scale factor, unit of measure and pulses per unit, making these meters the most straight-forward metering systems available in the industry.

OPERATION

The M7600 meters have stainless steel flow tubes with internal isolating linings. Two electromagnetic coils are located outside the flow tube, diametrically opposed to each other and protected by a carbon steel housing. Two electrodes, inserted into the flow tube, are positioned flush with the internal diameter of the tube and perpendicular to the coils. The coils are energized by a pulsed DC voltage provided by the electronic converter, and a magnetic field is generated across the flow tube section. According to Faraday's law, when this magnetic field is cut by the conductive liquid flowing through the meter, a voltage is generated in the liquid. This voltage is directly proportional to the liquid flow velocity, and therefore to the actual volumetric flow rate of the liquid. The electronic converter measures this voltage, processes the signal, and provides two digital pulse outputs, scalable to the desired volumetric value. These digital pulse outputs can be connected to a batch controller, a totalizer display unit for monitoring purposes, or to both devices simultaneously.

The operation of the M7600 meter is not affected by a moderate presence of most suspended solids in the liquid. Variations of liquid temperature, viscosity or density have no influence in the principle of operation.

APPLICATION

Because of its inherent advantages over other more conventional technologies, the M7600 meter can be used in the majority of industrial process batching applications and is the meter of choice for concrete batching operations. Whether the fluid is water or something very viscous, contains a moderate amount of solids or requires special handling, the M7600 meter will be able to accurately provide flow measurement.



FEATURES

- Sizes: 1/2...4 in.
- Standard accuracy $\pm 0.5\%$ of rate
- $\pm 0.1\%$ repeatability
- Open cross-section design: no pressure loss, no moving parts, no maintenance required
- Unaffected by the presence of most suspended solids in the liquid
- Pulsed DC magnetic field for maximum zero point stability
- Two standard pulse outputs: solid-state relay and open collector output, compatible with most batch controllers and totalizer displays
- Programmable scale factor
- Long life, corrosion-resistant liner (PTFE)
- NEMA 4 standard enclosure
- Complies with NIST Handbook HB44 for batching meters

SPECIFICATIONS

Performance

Sizes	Sizes 1/2...4 in. (15...100 mm)
Flow Range	0.14...1320 gpm (0.53...5000 lpm)
Accuracy	±0.5% of rate for velocities greater than 1.64 ft/s, ±0.008 ft/s less than 1.64 ft/s
	±0.5% of rate for velocities greater than 0.50 m/s, ±2.5 mm/s less than 0.50 m/s
	Note: The maximum measuring error depends on the installation conditions.
Repeatability	±0.1%
Fluid Temperature	Maximum fluid temperature: 212° F (100° C)
Storage Temperature	-40...140° F (-40...60° C)
Ambient Temperature	-4...140° F (-20...60° C)
Fluid Conductivity	Minimum liquid conductivity: 5 micromhos/cm
Flow Direction	Unidirectional
Pressure Limits	Working pressure: 232 psi (16 bar)

Materials of Construction

Flow Tube	AISI 316 stainless steel
Detector Housing	Flange material: carbon steel, enamel paint finishing
Liner Material	PTFE
End Connection	ANSI 150# carbon steel flanges
Electrodes Materials	Hastelloy C22
Amplifier Housing	Powder-coated cast aluminum, NEMA 4
	Meter mounted only
Cable Entries	Two 1/2 in. NPT cord grip
Grounding Rings	Standard (pre-installed)
Optional Grounding Electrodes	2

Inputs

Power Supply	92...275 VAC
Coil Excitation	Pulsed DC
Programming	PC user interface

Outputs

Digital Output	Output 1: solid-state relay up to 230V, 500 mA
	Output 2: Opto-isolated open collector, 50 mA at 24V DC
Frequency Output	Maximum output frequency: 10 kHz
Pulse Width	50% duty cycle

Approvals

Meter Enclosure	NEMA 4
NIST Handbook B44	Complies for batching applications

M7600 METER DIMENSIONS

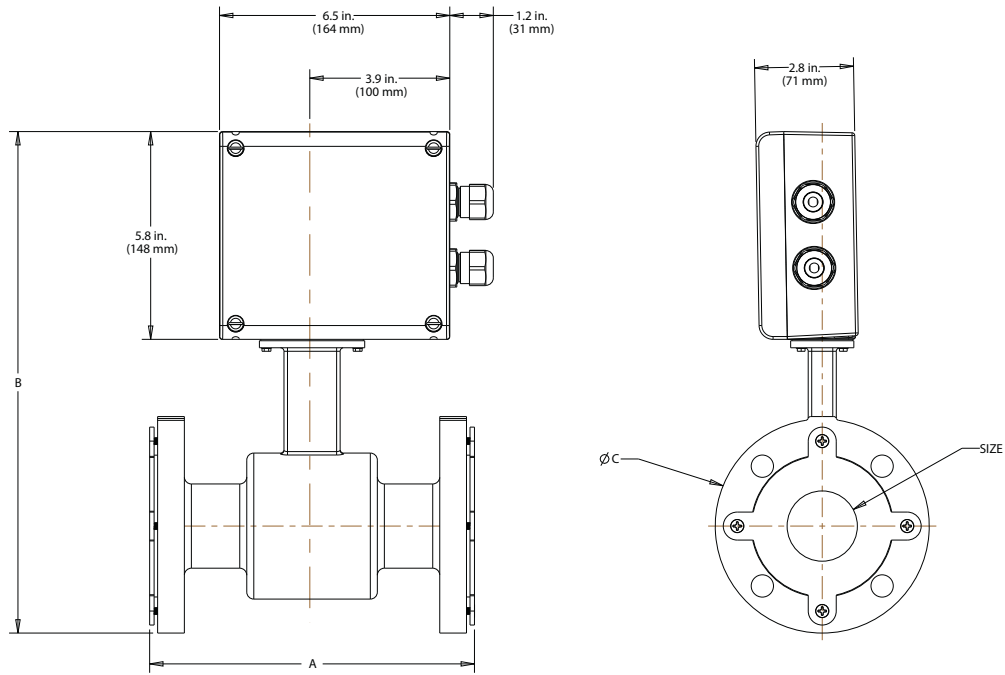

Size		A		B		C		Finish Est. Wt.		Flow Range			
inch	mm	inch	mm	inch	mm	inch	mm	lb	kg	GPM		LPM	
										min.	max.	min.	max.
1/2	15	6.9	176	12.9	327	3.5	89	8.4	3.81	0.14	33.5	0.53	127
1	25	9.1	231	13.3	337	4.3	108	10.52	4.77	0.35	84	1.32	318
2	50	10.0	254	14.7	374	6.0	152	18.63	8.45	1.57	375	15.96	1420
3	80	12.0	305	16.2	411	7.5	191	31.50	14.29	3.68	880	13.93	3330
4	100	14.0	356	17.2	437	9.0	229	43.85	19.89	5.52	1320	20.90	5000